

**The MK 100 mobile
construction crane.
The way forward.**



LIEBHERR



1 Compact and highly manoeuvrable.
The MK 100 mobile construction crane is very compact and extremely manoeuvrable. The driver's cabin affords a clear and unrestricted view. All five axles can be steered, for optimum manoeuvrability even when construction site conditions are difficult. Six electronic travel modes are available at the push of a button to assist the driver when manoeuvring in a variety of conditions.

2 Program-controlled one-man erecting.
The entire erecting procedure is fully program-controlled. The desired hook height is preselected, and the entire process of erecting the crane is then carried out and monitored automatically. Only one radio remote control lever needs to be operated. The MK 100 mobile construction crane is extremely stable in accordance with DIN 15019, and does not need to be disassembled when it is not in operation and the jib is horizontal. The crane is suitable for operation at wind speeds of up to 20 metres per second.

3 Comfort, convenience and high functional efficiency.
Both the modern driver's cabin and the variable-height lift cabin satisfy the latest ergonomic design requirements. High levels of functionality and comfort create perfect conditions for concentrated, safe working. All the controls are laid out ergonomically, for safe and efficient operation even in continuous use. The steplessly adjustable lift cabin offers a perfect view of the load.

4 Quality - down to the smallest detail.
Many of the individual components of this mobile construction crane have been specially designed for construction-site applications. Switchgear cabinet, winches, drives, slewing connection and controls have all been developed and manufactured by Liebherr. These in-house components are of advanced technical design and high quality combined with utmost benefits for the user.

1 Compact and extremely manoeuvrable.

The MK 100 mobile construction crane travels fully equipped with tower, jib, complete ballast, electrical generator and variable-height lift cabin. When ready for transport, the crane is only 16.65 m long, with a width of 3.0 m and a height of 4.0 m. It is not necessary to carry additional ballast.

Optimum manoeuvrability.

For optimum manoeuvrability, all five axles can be steered. Six electronic driving programs are available at the touch of a button to assist the driver when manoeuvring in a variety of situations. They include: road steering, all-wheel steering, diagonal travel, reduced swing-out, independent rear-axle steering and rear-axle steering locked out of use.



Modern powertrain and steering concept.

Variable steering concept with active rear-axle steering.

One of the major benefits of the MK 100's powertrain and steering concept is the speed-dependent active rear-axle steering which complies with high safety standards. Tyre wear is reduced and manoeuvrability significantly improved. Six steering modes can be selected via fixed programs.

Fast on the road.

The Liebherr 6-cylinder turbocharged diesel engine delivers 338 kW and makes this crane a fast mover. This robust, reliable engine complies with the EURO 3 emissions standard and is controlled by an electronic engine management system.

The AS-TRONIC automated-shift gearbox provides 12 forward and 2 reverse gears and helps to achieve a significant reduction in fuel consumption.

Other benefits: the automatic anti-lock system (ABV) enhances driving safety, the anti-slip regulation system (ASR) prevents the wheels from losing traction when the crane pulls away from a standstill. An Intarder is also standard equipment.

NIVEAUMATIC suspension.

The NIVEAUMATIC suspension system protects both the crane and the road surface. Cross-connection of the hydro-pneumatic suspension units guarantees stability when cornering. The vehicle's ride height can be automatically adjusted from any position to the target level at a pushbutton in the driver's cabin. Suspension travel of plus/minus 100 mm is available.

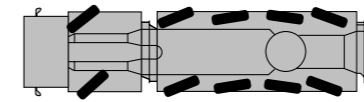

Road steering.

Axles 1 and 2 are steered mechanically from the steering wheel with hydraulic power assistance. Axles 3, 4 and 5 are "actively" steered according to the front wheel lock angle and the speed of the vehicle. At speeds above 30 km/h, axles 3 and 4 are locked in the straight-ahead position; axle 5 is locked at speeds above 60 km/h.

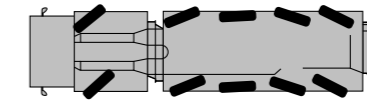

All-wheel steering.

Axles 3, 4 and 5 are steered from the steering wheel as a function of the wheel lock angle at axle 1. These axles are turned sufficiently to obtain the smallest possible turning circle.

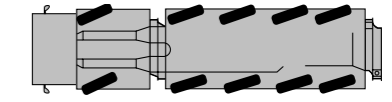

Diagonal travel.

Axles 3, 4 and 5 are turned from the steering wheel in the same direction as the axles 1 and 2.

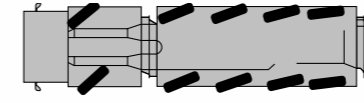

Reduced swing-out.

Axles 3, 4 and 5 are steered, depending on the wheel lock angle at axle 1, in such a way that rear end swing-out is reduced to a minimum.

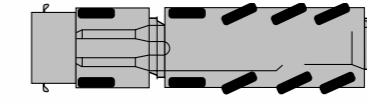

Independent rear-axle steering.

Axles 1 and 2 are steered from the steering wheel, axles 3, 4 and 5 are steered by means of buttons independently of the wheel lock angle at axles 1 and 2; the wheel lock angle of axle 3 is adjusted individually.

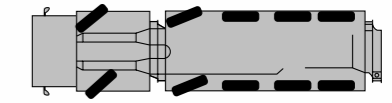

Disabled rear-axle steering.

Axles 3, 4 and 5 cannot be steered.

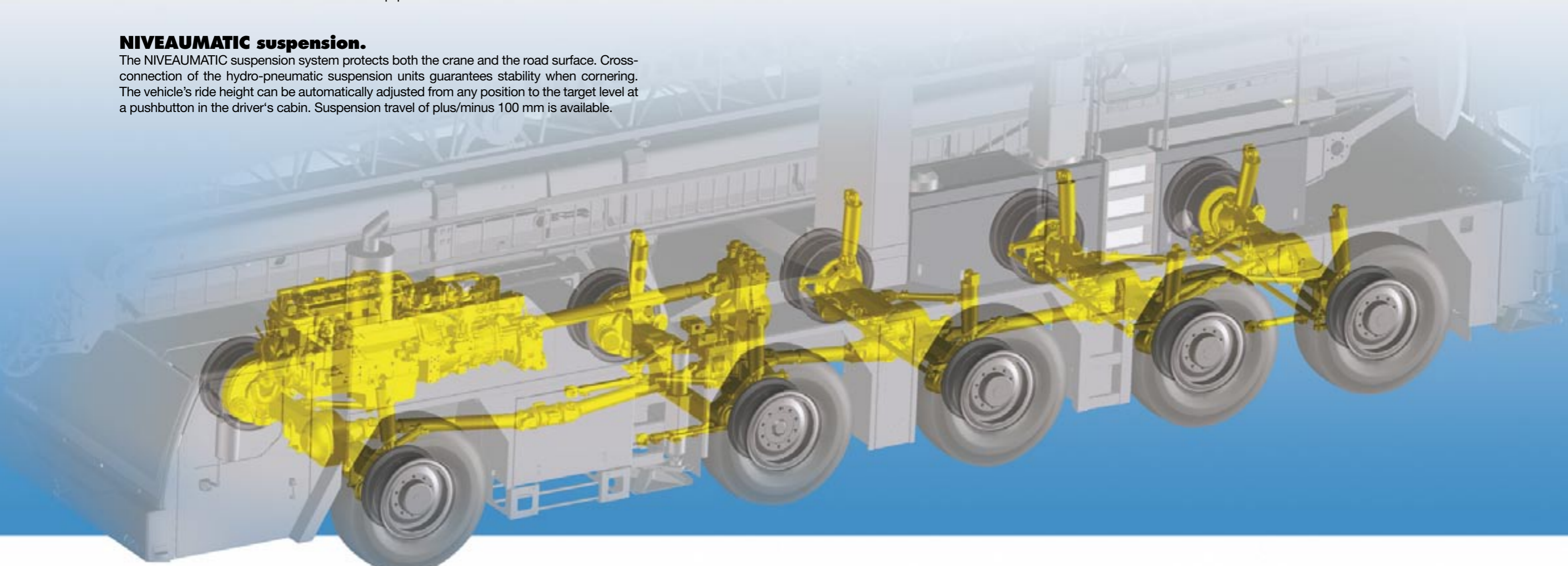



2 Program-controlled one-man erecting.

The MK 100 mobile construction crane is designed for one-man erecting at the push of a button. It can travel in the erected position. Depending on the chosen application, 3 different crane erecting curves are available. The desired hook height is preselected, and the entire program-controlled crane erecting process then takes place and is automatically monitored. The time needed for erecting the crane completely is only about 15 minutes.

The new torsionally rigid, solid walled tower with two-stage telescoping action provides hook heights of 25.0 m and 33.0 m with the jib horizontal or 54.0 m and 58.0 m when it is raised to a 30° angle.

The new erecting system reduces loads on the sliding guides of the telescopically extending tower. The system needs very little maintenance and guarantees a long service life.

The four-part telescopically extending jib is of a lattice construction and has a very narrow, high airborne erecting curve that occupies only a minimum space above the crane. It can be erected over obstacles with a height of up to 17.0 m. Jib length is variable and can be extended or retracted telescopically with program control from 44.0 m to 52.0 m.

The jib can be moved from its horizontal position to the 30° raised position within two minutes if required.

3 Comfort, convenience and high functional efficiency.

The modern driver's cab.

The modern driver's cab is a highly functional unit with a clear and unobstructed view of the road, an excellent level of comfort and thoroughly impressive design. Hydraulic damping, internal trim panels for noise and heat insulation and pneumatically sprung, continuously adjustable seats are all standard features of this new mobile construction crane. All the controls are arranged in an ergonomic layout, for safe, convenient operation even during lengthy working periods. Other comfort benefits include safety glass all around, heated and electrically adjustable outside mirrors, seat belts for driver and passenger, preparation for radio installation and various stowage shelves and compartments.

Variable-height lift cabin.

The MK 100's lift cabin has tempered safety glass windows all around. Its height can be continuously adjusted up to 30.0 m. It can now also be moved up and down the tower at a higher speed. Operation of the crane is possible in any cabin position. This is a key advantage, as it means that the load can be set down with pinpoint accuracy and the operator has the best possible view of the work area. The crane cabin offers exceptional comfort and user-friendliness and can also be equipped with camera systems. The user-friendly armrest controls, adjustable master-switch panels and master-switch armrests ensure that the operator does not tire on the job. This lift cabin has a front window that can be opened and has large wipers; there are roller sun blinds at the front and side windows.



4 Quality - down to the smallest detail.

Components of Liebherr's own manufacture, including the switchgear cabinet, winches, drives and slewing connection, are perfectly matched to construction-site requirements.

① Switchgear cabinet.

The decentral control technology and the frequency converters for the stepless drives used throughout are linked via CAN BUS to the switchgear cabinet. This technology increases functional efficiency and cost effectiveness even further, as well as offering benefits in terms of ease of maintenance and diagnostic capabilities.

② Mains-independent electric power supply.

Electric power for the MK 100 can either be taken from the mains supply or from an on-board diesel-engined generator rated at 57 kVA. This makes it possible to work on construction sites without being dependent on a mains power line.

③ Control and display panel.

The control panel for the complete erecting process is simple and has a very clear layout. It shows the displays and graduated scales for the crane sensors. All operational data are displayed here.

④ Electrical distribution.

The MK 100's highly versatile electrical power supply system has fault-current protection. The following connecting options are provided: three earthed power sockets, two 16 A connections and one 32 A connection.

⑤ Crane support control unit.

The crane is supported and automatically leveled at two control panels on the chassis. 5.95 m x 8.25 m or 8.2 m x 8.25 m support bases are available.



Powerful stepless FC drives.

All drive systems are integrated into the superstructure. The drives for the hoisting, erecting and trolley travel gear, jib guying winch and slewing gear are all supplied from frequency converters (FC) so that full stepless speed control is possible. High-performance winches manufactured by Liebherr handle the loads with precision. They have been specially designed for crane use and tested under harsh endurance-test conditions.

High-performance FC hoisting winch.

The frequency converter controlled high-performance hoisting winch provides an exceptionally broad range of speeds and performance levels. This enables the crane both to lift its maximum load at the hook, but also to achieve high off-load hook speeds.

The crane operates exclusively in the double-reeved mode. No time-intensive re-reeving work is required.

The hoisting gear is driven by Liebherr-built motors. Stepless control of their speed is possible. The key advantages of this system include automatic load detection, operation at micro-speeds, utilisation of the full control lever travel and the ability to stop the load without engagement of the hoisting gear brake. A positioning mode is also available.

FC slewing gear.

The FC slewing gear drive permits totally jerk and judder-free slewing movement, with micro-speeds available. Electronic wind load regulation detects and suppresses wind and load influences. The automatic load vibration damping system identifies and prevents vibration in the crane and oscillation of the load. Counter-current can be applied in absolute safety.

FC trolley travel gear.

The Liebherr FC trolley travel gear is notable for impressively smooth, stepless movement, with a wide performance range and high trolley travel speeds, particularly under load.



Liebherr's own high-performance winches.

The drive assemblies are easily accessible for servicing.

The MK 100 has stepless trolley travel speeds. All loads are lifted in the double-reeved mode.

Overview of performance data.



Variable-height lift cabin

- Stepless height adjustment up to 30.0 m
- Best possible view of the work area
- Operation of the crane is possible in all cabin positions
- Safety glass windows all round
- User-friendly armrest controls
- Ergonomic control levers
- Wash/wipe system
- Roller sun blinds
- Preparation for radio

Technical data and specifications

Telescopic jib	44.0 m/52.0 m
Hook height	25.0 m/33.0 m
Hook heights with jib at 30° angle	54.0 m/58.0 m
Max. lifting capacity	8,000 kg
Load at jib end	1,600 kg

Stability

- Crane stability maintained at wind speeds of up to 20 m/s
- No disassembly required when not in operation
- Additional ballast of 2.35 t possible

Drives

Infinitely variable drives	
Hoisting and erecting winch	30 kW, FC
Trolley travel winch	4.0 kW, FC
Slewing gear	7.5 kW, FC
Generator	57 kVA

Controls

Operating range restriction ABB (optional)
Load moment limiting LMB

Chassis

- Transport with all equipment in place
- Can be driven in the upright position
- Large slope clearance angle of up to 12°
- Minimum turning circle 11.28 m with all-wheel steering
- Large 14.00 R25 tyres: generous ground clearance, reduced wear

Powertrain and steering

- Powerful Liebherr 6-cylinder 338 kW turbocharged diesel engine
- Automated-shift AS-TRONIC gearbox
- 12 forward and 2 reverse gears
- Low fuel consumption
- Two-speed transfer box with lockable differential
- Intarder
- Permanent drive to axles 1, 3 and 4, optional drive to axle 5
- Automatic anti-lock system ABV
- Anti-slip regulation system ASR
- Six steering modes: road steering, all-wheel steering, diagonal travel, reduced swing-out, independent rear-axle steering, rear-axle steering locked
- NIVEAUMATIC hydro-pneumatic suspension
- Max. road speed: 75 km/h

Supports

- Variable support base, 5.95 m and 8.20 m
- Fully-automatic levelling system
- Control panels on both sides
- Support pressure display (optional)

Comfortable driving cabin

- Modern design, high level of functionality
- Unobstructed view of the road
- Safety glass windows all round
- Digital display and keypad units
- Pneumatically sprung driver's and co-driver's seats
- Heated and electrically adjustable outside mirrors
- Seat belts for driver and passenger
- Windshield wiper with automatic wash/wipe function